

**THERMOBILE**  
**DEHUMIDIFIERS**

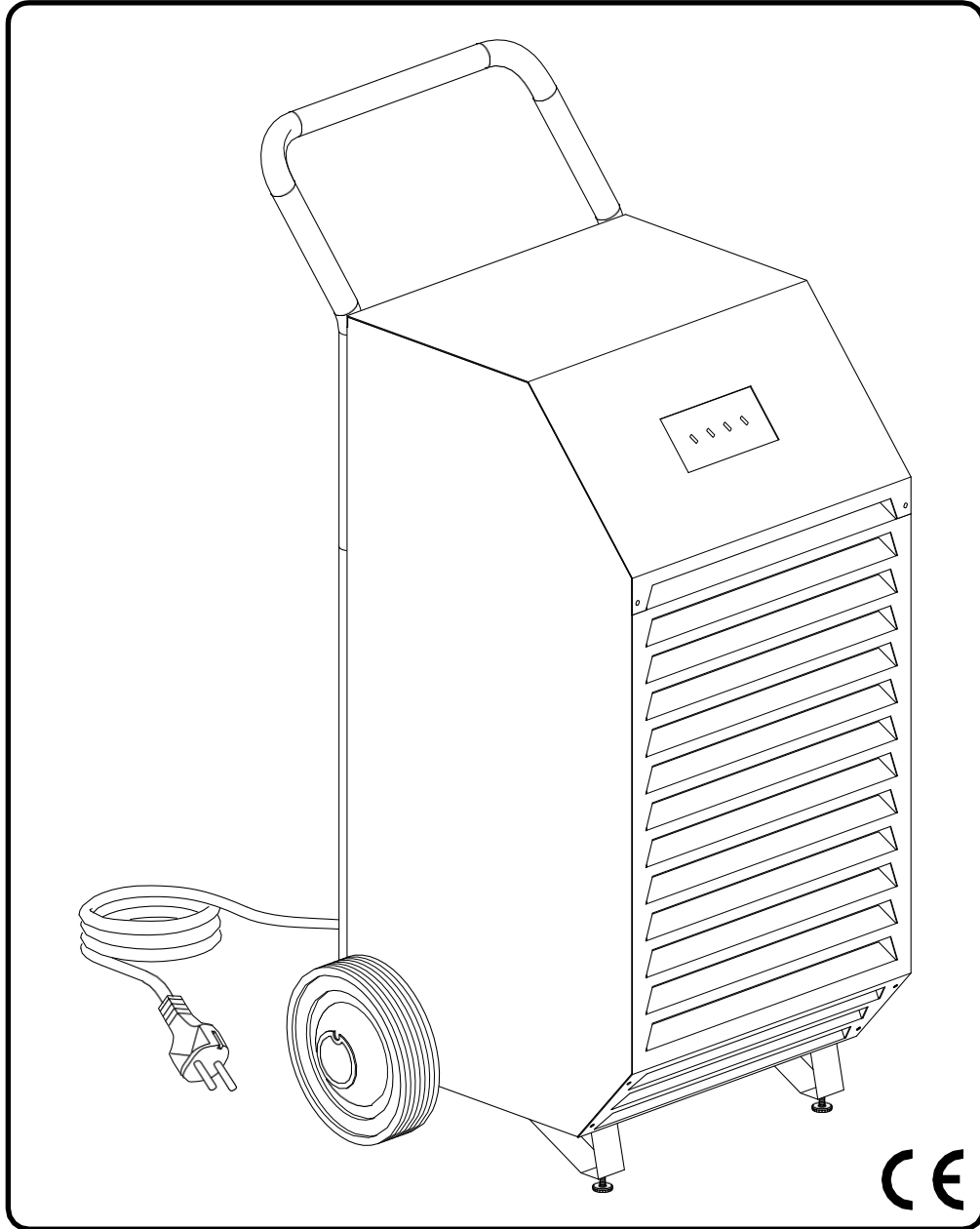

**GB**

***SUPER DRYER***  
***FDSDP 62***

**SPARE PARTS DISASSEMBLY**

# SPARE PARTS DISASSEMBLY

## SUPER DRYER

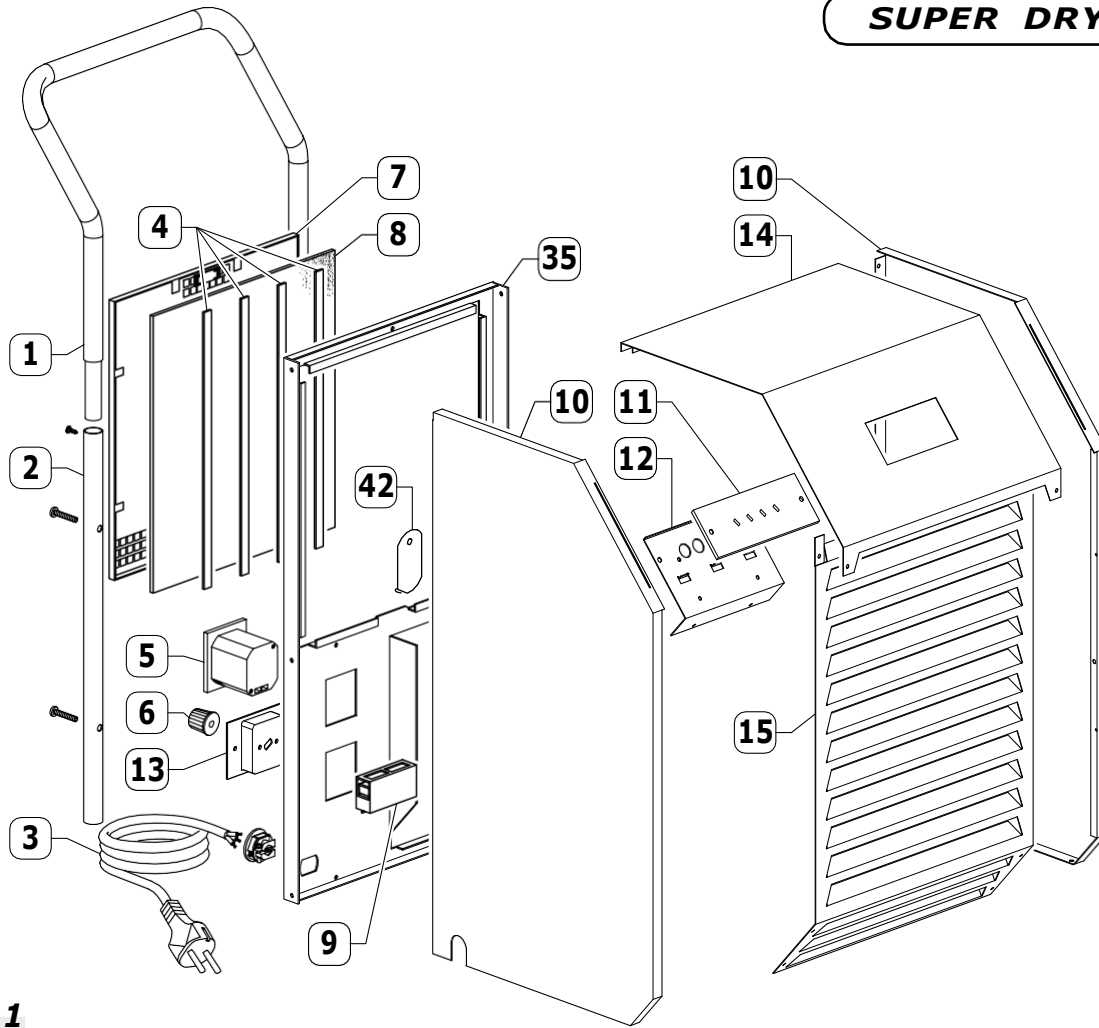
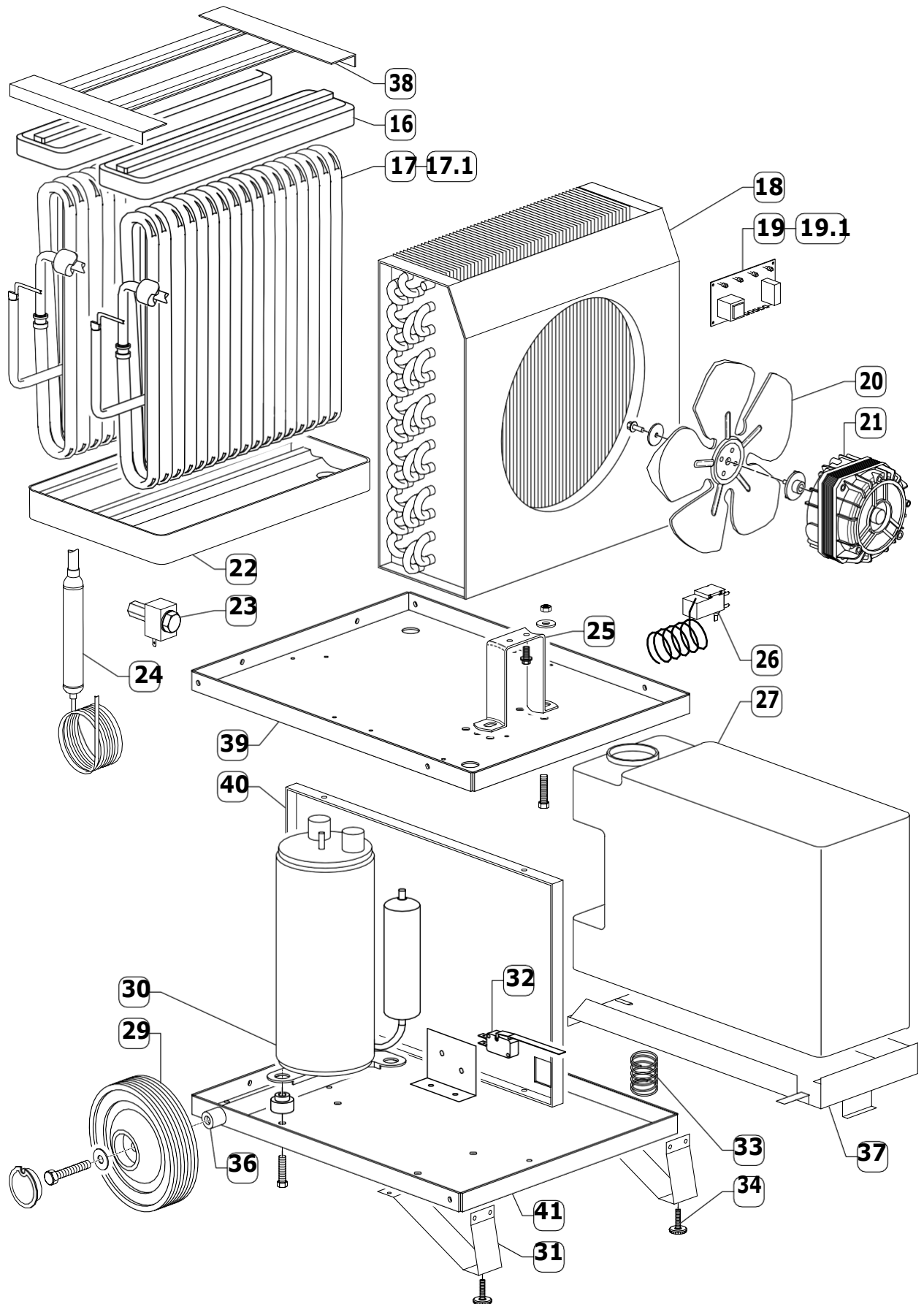

Fig. 1

Pos.	Description	Q.ty	Pos.	Description	Q.ty
1	Handle	1	22	Lower condensate collecting tray	1
2	Handle pipe	2	23*	<b>Solenoid valve (vers.S)</b>	1
3	Cable	1	24	Refrigerant filter with capillary	1
4	Filter holder	4	25	Fan braket	1
5	Hour counter	1	26*	<b>Thermostat(vers. S)</b>	1
6	Knob	1	27	Tank	1
7	Filter seat	1	29	Wheel	2
8	Air filter	1	30	Compressor	1
9	Dehumidostat	1	31	Foot	2
10	Side panel	1+1	32	Support with microswitch	1
11	Control panel with silkscreen printing	1	33	Sprig	2
12	Support PCB	1	34	Under foot support	2
13	Support dehumidostat	1	35	Back panel	1
14	Cover	1	36	Axil wheel	1
15	Front grille	1	37	Tank support	1
16	Top try	2	38	Support evaporator	1
17	Evaporator	1	39	Plane intermediate	1
17.1*	<b>Evaporator (vers.S)</b>	1	40	Vertical panel	1
18	Condenser	1	41	Bottom panel	1
19	Electronic card	1	42	Lock block	1
19.1*	<b>Electronic card (vers.S)</b>	1			
20	Impeller	1			
21	Motorfan	1	(*)	<b>Parts for Hot gas thefrosting version (vers. S)</b>	

# SPARE PARTS DISASSEMBLY

**SUPER DRYER**



**Fig. 2**

